

Brushless DC Motor Systems

AXU Series

The **AXU** Series combines a compact, brushless DC motor with a speed control unit. These systems provide space savings, easy wiring and simple operation.



Features

● Easy Connection and Simple Operation

Just connect the motor connector to the control unit, and the **AXU** is ready for immediate use. The rate of rotation is easy to adjust using the speed control dial on the front of the speed control unit.

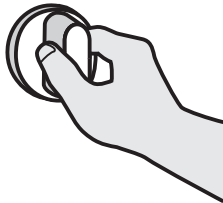

● Thin and Compact

Compared to an AC speed control motor, the use of a brushless DC motor significantly reduces the size of the motor.

Motor Length: 1.65 inch (42 mm) for 10 W, 25 W
2.24 inch (57 mm) for 40 W, 90 W

● Wide Speed Range and Constant Torque

Even with an available speed range of 100~2000 r/min, the **AXU** Series motor maintains a constant torque.

● External Control Possible

Run/Stop, rotation direction and instantaneous stops can be controlled with external signals.

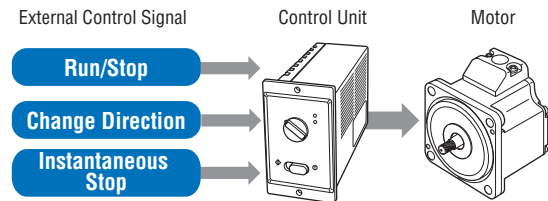

● Superior Speed Stability

Speed regulation characteristics are -2% maximum with load, $\pm 1\%$ maximum with voltage and $\pm 1\%$ maximum with temperature.

● Acceleration/Deceleration Functions

AXU Series motors can be set to accelerate and decelerate when the start and stop input is used.

● Protective Functions

The **AXU** Series is equipped with protective functions to handle overload, overvoltage, out-of-phase, undervoltage and overspeed. When an abnormality is detected, an alarm is output and the motor comes to a stop.

● Motor Construction IP65

A grade IP65 indicates protection against jets of water. It is safety if get splashed accidentally. However it is not suitable for washing the motor nor being operated under the circumstance of being splashed constantly.

Safety Standards and CE Marking

	Standards	Certification Body	Standards File No.	CE Marking
Motor	UL1950	UL	E208200	Low Voltage Directives EMC Directives
	CSA C22.2 No.950			
	EN60950	Conform to EN/IEC Standards		
	EN60034-1			
	EN60034-5			
Control Unit	UL508C	UL	E171462	
	CSA C22.2 No.14			
	EN60950	Conform to EN/IEC Standards		
	EN50178			

● When the system is approved under various safety standards, the model names on the motor and control unit nameplates are the approved model names.

● **List of Motor and Control Unit Combinations** → Page B-57

● **Details of Safety Standards** → Page G-2

● The EMC value changes according to the wiring and layout. Therefore, the final EMC level must be checked with the motor/control unit incorporated in the equipment.

System Configuration

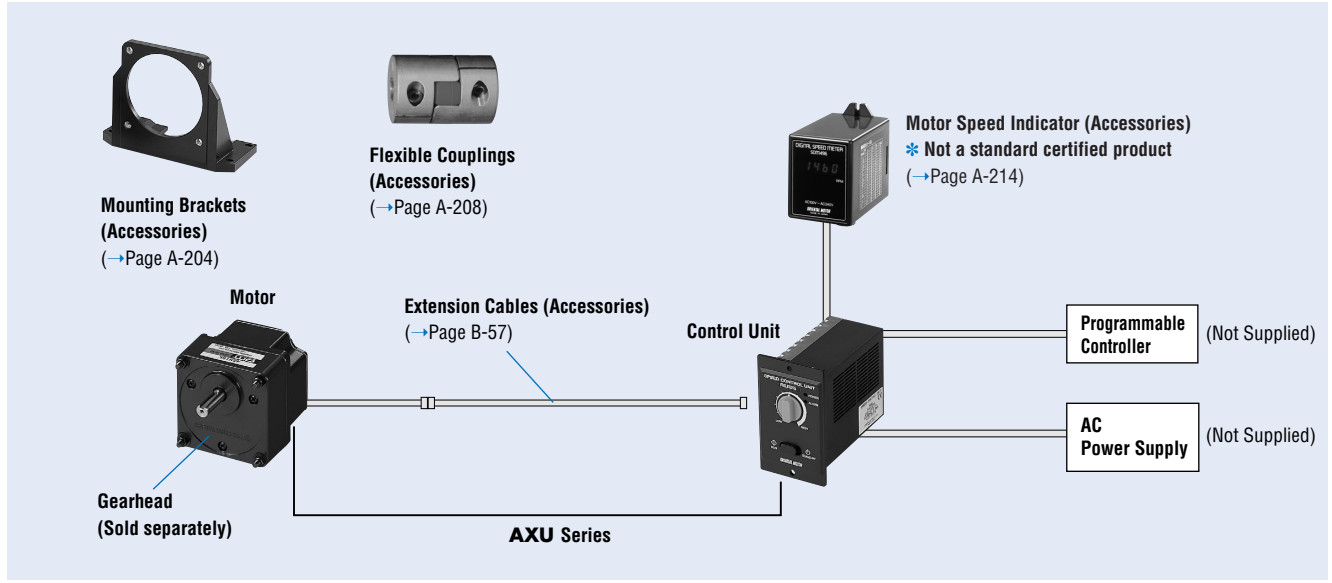

The system configuration shown is an example. Other configurations are available.

Product Number Code

Motor and Control Unit

AXU 4 25 A - GN

Series
AXU: AXU Series

Motor Frame Size
2: 2.36 in. sq. (60 mm sq.)
4: 3.15 in. sq. (80 mm sq.)
5: 3.54 in. sq. (90 mm sq.)

Output Power
10: 10 W (1/75 HP)
25: 25 W (1/30 HP)
40: 40 W (1/19 HP)
90: 90 W (1/8 HP)

Voltage
A: Single-Phase 100-115 VAC
C: Single-Phase 200-230 VAC
S: Three-Phase 200-230 VAC

Shaft Type
GN: Pinion Shaft (for use with GN gearhead)
GU: Pinion Shaft (for use with GU gearhead)
A: Round Shaft

Gearhead

4 GN 50 KA

Type of Bearings and Shaft Size
KA: Ball bearing type and inch-sized output shaft
KHA: Ball bearing type and inch-sized output shaft for higher torque

Gear Ratio
(Example) 50: Gear ratio of 50:1
10X: Denotes decimal gearhead with 10:1 gear ratio

Gearhead Type
GN: GN type (for use with GN-type pinion shaft motor)
GU: GU type (for use with GU-type pinion shaft motor)

Gearhead Frame Size
2: 2.36 in. sq. (60 mm sq.)
4: 3.15 in. sq. (80 mm sq.)
5: 3.54 in. sq. (90 mm sq.)

• Gearheads must match the motor installation dimensions and shaft type.

Product Line

AXU Series

Output Power HP	W	Power Supply Voltage	Model	
			Pinion Shaft	Round Shaft
1/75	10	Single-Phase 100-115 VAC	AXU210A-GN	AXU210A-A
		Single-Phase 200-230 VAC	AXU210C-GN	AXU210C-A
		Three-Phase 200-230 VAC	AXU210S-GN	AXU210S-A
1/30	25	Single-Phase 100-115 VAC	AXU425A-GN	AXU425A-A
		Single-Phase 200-230 VAC	AXU425C-GN	AXU425C-A
		Three-Phase 200-230 VAC	AXU425S-GN	AXU425S-A
1/19	40	Single-Phase 100-115 VAC	AXU540A-GN	AXU540A-A
		Single-Phase 200-230 VAC	AXU540C-GN	AXU540C-A
		Three-Phase 200-230 VAC	AXU540S-GN	AXU540S-A
1/8	90	Single-Phase 100-115 VAC	AXU590A-GU	AXU590A-A
		Single-Phase 200-230 VAC	AXU590C-GU	AXU590C-A
		Three-Phase 200-230 VAC	AXU590S-GU	AXU590S-A

Gearheads (Sold Separately)

Gearhead Model	Gear Ratio
2GN□KA	3~180
2GN10XK (Decimal Gearhead)	
4GN□KA	3~180
4GN10XK (Decimal Gearhead)	
5GN□KA	3~180
5GN10XK (Decimal Gearhead)	
5GU□KA	3~180
5GU10XKB (Decimal Gearhead)[for 5GU□KA]	
5GU□KHA (High Power Type)	50~180
5GU10XK (Decimal Gearhead)[for 5GU□KHA]	

• Enter the appropriate gear ratio in the box (□) within the gearhead model name.

Specifications

Package Model	Pinion Shaft Type	AXU210A-GN	AXU210C-GN	AXU210S-GN	AXU425A-GN	AXU425C-GN	AXU425S-GN
	Round Shaft Type	AXU210A-A	AXU210C-A	AXU210S-A	AXU425A-A	AXU425C-A	AXU425S-A
Rated Output Power	HP (W)	1/75 (10)			1/30 (25)		
Power Source	Voltage	Single-Phase 100-115 VAC±10%	Single-Phase 200-230 VAC±10%	Three-Phase 200-230 VAC±10%	Single-Phase 100-115 VAC±10%	Single-Phase 200-230 VAC±10%	Three-Phase 200-230 VAC±10%
	Frequency	50/60 Hz					
	Rated Input Current A	0.7	0.4	0.25	1.1	0.65	0.4
	Maximum Input Current A	0.9	0.6	0.4	1.5	0.9	0.7
Rated Torque	oz-in (N·m)	7.1 (0.05)			17.7 (0.125)		
Starting Torque	oz-in (N·m)	8.5 (0.06)			21 (0.15)		
Permissible Load Inertia J *	oz-in ² (×10 ⁻⁴ kg·m ²)	2.7 (0.5)			9.8 (1.8)		
Rated Speed	r/min	2000					
Variable Speed Range	r/min	100~2000 (speed ratio 20:1)					
Speed Regulation	Load	-2% Max. (0~ rated torque, at rated speed)					
	Voltage	±1% Max. (power supply voltage ±10 %, at rated speed with no load)					
	Temperature	±1% Max. (32°F~104°F [0°C~+40°C] at rated speed with no load)					

Package Model	Pinion Shaft Type	AXU540A-GN	AXU540C-GN	AXU540S-GN	AXU590A-GU	AXU590C-GU	AXU590S-GU
	Round Shaft Type	AXU540A-A	AXU540C-A	AXU540S-A	AXU590A-A	AXU590C-A	AXU590S-A
Rated Output Power	HP (W)	1/19 (40)			1/8 (90)		
Power Source	Voltage	Single-Phase 100-115 VAC±10%	Single-Phase 200-230 VAC±10%	Three-Phase 200-230 VAC±10%	Single-Phase 100-115 VAC±10%	Single-Phase 200-230 VAC±10%	Three-Phase 200-230 VAC±10%
	Frequency	50/60 Hz					
	Rated Input Current A	1.65	1.0	0.5	2.5	1.45	0.8
	Maximum Input Current A	2.1	1.3	0.8	3.3	2.0	1.2
Rated Torque	oz-in (N·m)	28 (0.20)			63 (0.45)		
Starting Torque	oz-in (N·m)	34 (0.24)			76 (0.54)		
Permissible Load Inertia J *	oz-in ² (×10 ⁻⁴ kg·m ²)	18.1 (3.3)			32 (5.8)		
Rated Speed	r/min	2000					
Variable Speed Range	r/min	100~2000 (speed ratio 20:1)					
Speed Regulation	Load	-2% Max. (0~ rated torque, at rated speed)					
	Voltage	±1% Max. (power supply voltage ±10 %, at rated speed with no load)					
	Temperature	±1% Max. (32°F~104°F [0°C~+40°C] at rated speed with no load)					

* The Permissible Load Inertia specified above is only applicable to round shaft types. Permissible Load Inertia for Gearmotor Type →Page B-50

Common Specifications

Item	Specifications
Acceleration/Deceleration Time	0.5~10 sec. (at 2,000 r/min with no load) set by a potentiometer
Speed Control Method	Speed potentiometer on front panel
Input Signal	Photocoupler Input, Input Impedance 2 kΩ, Operated by internal power supply Common Clockwise (CW) and Counterclockwise (CCW) Inputs
Output Signal	Open Collector Output, External Use Condition 26.4 VDC, 10 mA Max. Speed Signal Output (SPEED OUT) 30 P/R, Alarm Signal Output (ALARM OUT)
Protection Functions *1	When the following are activated, the alarm signal will be output and the motor will come to a stop: <ul style="list-style-type: none"> ● Overload Protection: Activated when the motor load exceeds rated torque for a minimum of 5 seconds. ● Overvoltage Protection: Activated when the voltage applied to the control unit exceeds 115 VAC or 230 VAC by a minimum of 20%. ● Out-of-Phase Protection: Activated when motor signals are abnormal, due to disconnection of cable. ● Undervoltage Protection: Activated when the voltage applied to the control unit falls below 100 VAC or 200 VAC by a minimum of 30%. ● Overspeed Protection: Activated when the speed exceeds 2800 r/min.
Motor Insulation Class	Class E (248°F [120°C]) *2
Rating	Continuous

*1 Motor speed cannot be controlled in applications where the motor's shaft is turned by the load, as in lowering operations. To prevent damage to the driver during lowering operations, the motor comes to a natural stop if the primary voltage of the driver's inverter exceeds the permissible value.

*2 Motor insulation is recognized as Class A [221°F (105°C)] by UL and CSA standards.

General Specifications

Item	Motor	Control Unit
Insulation Resistance	100 MΩ or more when 500 VDC megger is applied between the windings and the frame.	100 MΩ or more when 500 VDC megger is applied between the power supply input terminal and the ground terminal, and between the power supply input terminal and the I/O terminal.
Dielectric Strength	Sufficient to withstand 1.5 kVAC at 50 Hz applied between the windings and the frame for 1 minute.	Sufficient to withstand 1.8 kVAC at 50 Hz applied between the ground terminal and the power supply input terminal for 1 minute, and 3 kVAC at 50 Hz applied between the ground terminal and the I/O terminal for 1 minute.
Operating Environment	Ambient Temperature: 32°F~122°F (0°C~+50°C)* (nonfreezing)	32°F~104°F (0°C~+40°C)*(nonfreezing)
Conditions	Humidity: 85% maximum (noncondensing)	
	Atmosphere: No corrosive gases or dust	
Degree of Protection	IP65 (except for the mounting surface)	IP10

- For round shaft types: Please attach to the following sizes of heat sinks to maintain a maximum motor housing temperature of 194 °F (90 °C)
 - **AXU210□-A**: 5.31 in. ×5.31 in. (135 mm×135 mm), 0.20 in. (5 mm) thick
 - **AXU425□-A**: 6.50 in. ×6.50 in. (165 mm×165 mm), 0.20 in. (5 mm) thick
 - **AXU540□-A**: 7.87 in. ×7.87 in. (200 mm×200 mm), 0.20 in. (5 mm) thick
 - **AXU590□-A**: 7.87 in. ×7.87 in. (200 mm×200 mm), 0.20 in. (5 mm) thick
- * Ambient temperature of the motor is recognized as 32 °F~104 °F (0 °C~+40 °C) by UL and CSA Standards.

Gearmotor–Torque Table

- Maximum Torque When Using a Decimal Gearhead
- **2GN□KA** with **2GN10XK**: 26 lb-in (3 N·m)
 - **4GN□KA*** with **4GN10XK**: 70 lb-in (8 N·m)
 - **5GN□KA** with **5GN10XK**: 88 lb-in (10 N·m)
 - **5GU□KA** with **5GU10XKB**: 177 lb-in (20 N·m)
 - **5GU□KHA** with **5GU10XK**: 260 lb-in (30 N·m)
- * All gear ratios except 25:1, 30:1, 36:1: 53 lb-in (6 N·m) Unit=Upper Values: lb-in/Lower Values: N·m

Model Motor/Gearhead	Speed Range r/min	Gear Ratio																			
		33	28	20	17	13	11	8	6.7	5.6	4	3.3	2.8	2	1.7	1.3	1.1	1	0.83	0.67	0.56
		667	556	400	333	267	222	160	133	111	80	67	56	40	33	27	22	20	17	13	11
AXU210A-GN AXU210C-GN AXU210S-GN / 2GN□KA		1.06	1.32	1.77	2.1	2.6	3.1	4.5	5.3	6.4	8.0	9.7	11.5	15	17.7	22	26	26	26	26	
		0.12	0.15	0.2	0.24	0.3	0.36	0.51	0.61	0.73	0.91	1.1	1.3	1.7	2	2.5	3	3	3	3	
AXU425A-GN AXU425C-GN AXU425S-GN / 4GN□KA		2.6	3.1	4.5	5.3	6.7	8.0	11.5	13.2	15.9	20	23	29	36	44	54	65	70	70	70	
		0.3	0.36	0.51	0.61	0.76	0.91	1.3	1.5	1.8	2.3	2.7	3.3	4.1	5	6.2	7.4	8	8	8	
AXU540A-GN AXU540C-GN AXU540S-GN / 5GN□KA		4.3	5.1	7.1	8.5	10.6	13.2	17.7	21	25	32	38	46	58	69	87	88	88	88	88	
		0.49	0.58	0.81	0.97	1.2	1.5	2.0	2.4	2.9	3.7	4.4	5.3	6.6	7.9	9.9	10	10	10	10	
AXU590A-GU AXU590C-GU AXU590S-GU / 5GU□KA		9.7	11.5	15.9	19.4	23	29	36	43	52	65	78	94	131	157	176	177	177	177	177	
		1.1	1.3	1.8	2.2	2.7	3.3	4.1	4.9	5.9	7.4	8.9	10.7	14.9	17.8	19.9	20	20	20	20	
AXU590A-GU AXU590C-GU AXU590S-GU / 5GU□KHA		—	—	—	—	—	—	—	—	—	—	—	—	131	157	176	210	230	260	260	
		—	—	—	—	—	—	—	—	—	—	—	—	14.9	17.8	19.9	23.9	26.6	30	30	

- Enter the appropriate gear ratio in the box (□) within the gearhead model name.
- A colored background indicates gear shaft rotation in the same direction as the motor shaft; a white background indicates rotation in the opposite direction.
- **KA** type is standard gearhead. **KHA** type is high-powered gearhead.

Permissible Overhung Load and Permissible Thrust Load

Gearheads

Model	Gear Ratio	Permissible Overhung Load				Permissible Thrust Load	
		0.39 in. (10 mm) from shaft end		0.79 in. (20 mm) from shaft end			
		lb.	N	lb.	N	lb.	N
2GN□KA	3~18	11.2	50	18	80	6.7	30
	25~180	27	120	40	180		
4GN□KA	3~18	22	100	33	150	11.2	50
	25~180	45	200	67	300		
5GN□KA	3~18	56	250	78	350	22	100
	25~180	67	300	101	450		
5GU□KA	3~9	90	400	112	500	33	150
	12.5~18	101	450	135	600		
	25~180	112	500	157	700		
5GU□KHA	50~180	90	400	135	600	33	150

- Enter the gear ratio in the box (□) within the model name.
- **KA** type is standard gearhead. **KHA** type is high-powered gearhead.

● Round Shaft Type

Model	Permissible Overhung Load			
	0.39 in. (10 mm) from shaft end		0.79 in. (20 mm) from shaft end	
	lb.	N	lb.	N
AXU210 □-A	15.7	70	22	100
AXU425 □-A	27	120	31	140
AXU540 □-A	36	160	38	170
AXU590 □-A	36	160	38	170

- Enter the appropriate letter in the box (□) within the motor model name. (**A**: Single-phase 100-115 VAC, **C**: Single-phase 200-230 VAC, **S**: Three-phase 200-230 VAC).
- Permissible Thrust Load: Avoid thrust loads as much as possible. If a thrust load is unavoidable, keep it to no more than half the motor weight.

■ Permissible Load Inertia J

Unit=Upper Values: oz-in²/Lower Values: ×10⁻⁴ kg-m²

Model Motor/Gearhead	Gear Ratio	3	3.6	5	6	7.5	9	12.5	15	18	25	30	36	50	60	75	90	100	120	150	180
AXU210 □-GN/2GN□KA		3.1 0.558	4.4 0.804	8.5 1.55	12.2 2.23	19.1 3.49	27 5.02	53 9.69	77 14	110 20.1	210 38.8	310 55.8	440 80.4	850 155	850 155	850 155	850 155	850 155	850 155	850 155	850 155
AXU425 □-GN/4GN□KA		10.8 1.98	15.6 2.85	30 5.5	43 7.92	68 12.4	97 17.8	188 34.4	270 49.5	390 71.3	750 138	1080 198	1560 285	3000 550	3000 550	3000 550	3000 550	3000 550	3000 550	3000 550	3000 550
AXU540 □-GN/5GN□KA		19.7 3.6	28 5.18	55 10	79 14.4	123 22.5	177 32.4	340 62.5	490 90	710 130	1370 250	1970 360	2800 518	5500 1000	5500 1000	5500 1000	5500 1000	5500 1000	5500 1000	5500 1000	5500 1000
AXU590 □-GU/5GU□KA		49 9	71 13	137 25	197 36	310 56.3	440 81	850 156	1230 225	1770 324	3400 625	4900 900	7100 1296	13700 2500	13700 2500	13700 2500	13700 2500	13700 2500	13700 2500	13700 2500	13700 2500
AXU590 □-GU/5GU□KHA		—	—	—	—	—	—	—	—	—	—	—	—	13700 2500	13700 2500	13700 2500	13700 2500	13700 2500	13700 2500	13700 2500	13700 2500

- Enter the appropriate letter in the box (□) within the motor model name. (**A**: Single-phase 100-115 VAC, **C**: Single-phase 200-230 VAC, **S**: Three-phase 200-230 VAC).
- Enter the appropriate gear ratio in the box (□) within the gearhead model name.

■ Speed-Torque Characteristics

AXU210A-GN/AXU210C-GN/AXU210S-GN
AXU210A-A/AXU210C-A/AXU210S-A

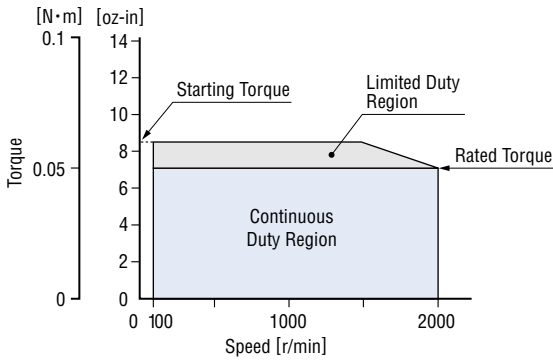

AXU425A-GN/AXU425C-GN/AXU425S-GN
AXU425A-A/AXU425C-A/AXU425S-A

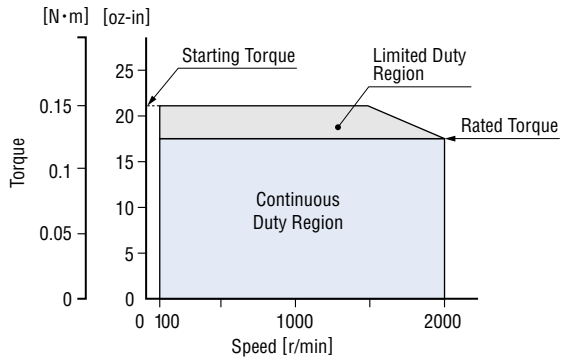

AXU540A-GN/AXU540C-GN/AXU540S-GN
AXU540A-A/AXU540C-A/AXU540S-A

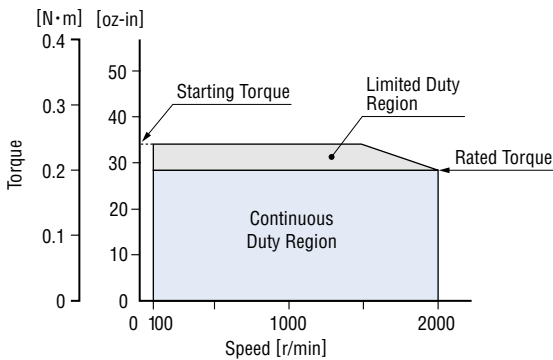

AXU590A-GU/AXU590C-GU/AXU590S-GU
AXU590A-A/AXU590C-A/AXU590S-A

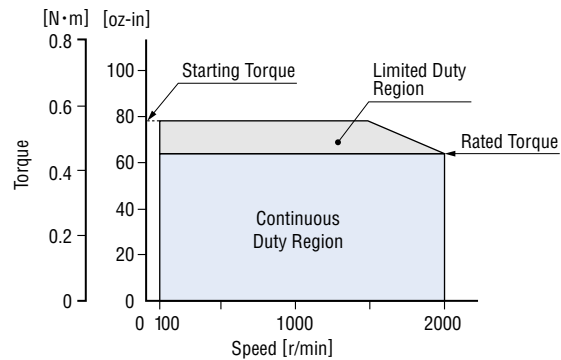

Dimensions Scale 1/4, Unit = inch (mm)

Mounting screws are included with gearheads. Dimensions for screws → Page B-133

Motor/Gearhead

AXU210A-GN, AXU210C-GN, AXU210S-GN Pinion Shaft Type

Motor: AXUM210-GN / Gearhead: **2GN□KA**
 Weight: 1.1 lb. (0.5 kg) / Weight: 0.88 lb. (0.4 kg)

DXF A289AU (**2GN3KA~18KA**)
 A289BU (**2GN25KA~180KA**)

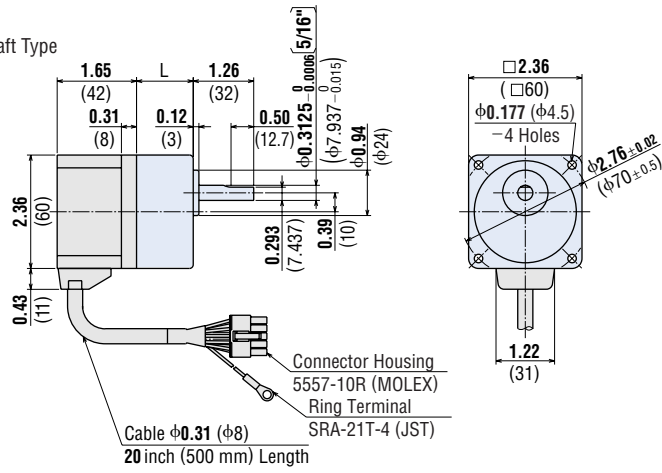

2GN3KA~18KA: L = 1.18 (30)
2GN25KA~180KA: L = 1.57 (40)

Round Shaft Type

AXU210A-A, AXU210C-A, AXU210S-A Round Shaft Type

Motor: AXUM210-A
 Weight: 1.1 lb. (0.5 kg)

DXF A316

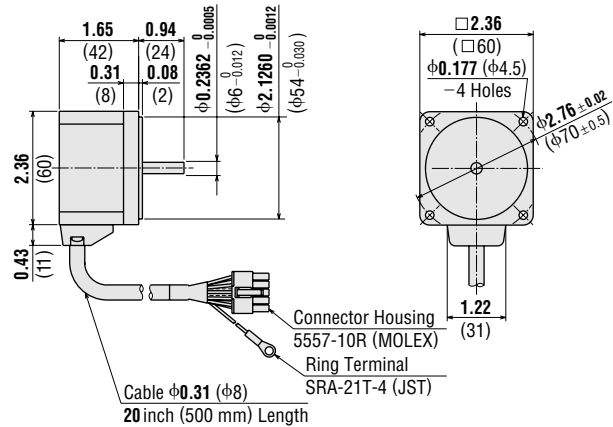

Decimal Gearhead

(Can be connected to **AXU210GN** pinion shaft type.)

2GN10XX
 Weight: 0.44 lb. (0.2 kg)

DXF A003



Motor/Gearhead

AXU425A-GN, AXU425C-GN, AXU425S-GN Pinion Shaft Type

Motor: AXUM425-GN / Gearhead: **4GN□KA**
 Weight: 1.76 lb. (0.8 kg) / Weight: 1.43 lb. (0.65 kg)

DXF A291AU (**4GN3KA~18KA**)
 A291BU (**4GN25KA~180KA**)

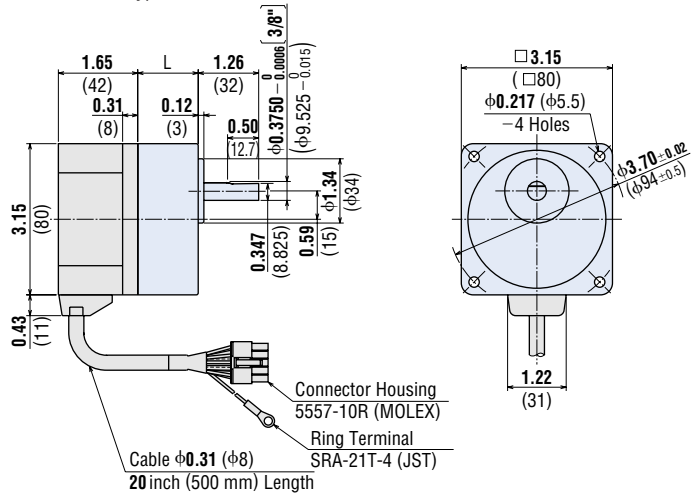

4GN3KA~18KA: L = 1.26 (32)
4GN25KA~180KA: L = 1.67 (42.5)

◆ Round Shaft Type

AXU425A-A, AXU425C-A, AXU425S-A Round Shaft Type

Motor: AXUM425-A

Weight: 1.76 lb. (0.8 kg)

DXF A317

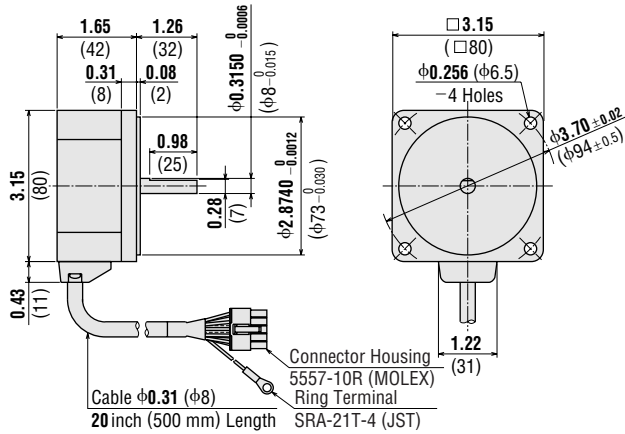

◆ Decimal Gearhead

(Can be connected to **AXU425GN** pinion shaft type.)

4GN10XK

Weight: 0.88 lb. (0.4 kg)

DXF A013

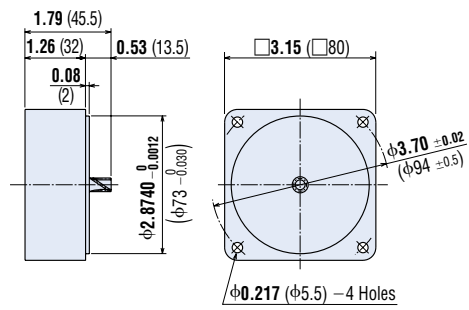

◆ Motor/Gearhead

AXU540A-GN, AXU540C-GN, AXU540S-GN Pinion Shaft Type

Motor
AXUM540-GN

Gearhead
5GN□KA

Weight: 3.1 lb. (1.4 kg)

Weight: 3.3 lb. (1.5 kg)

DXF A313AU (**5GN3KA~18KA**)
A313BU (**5GN25KA~180KA**)

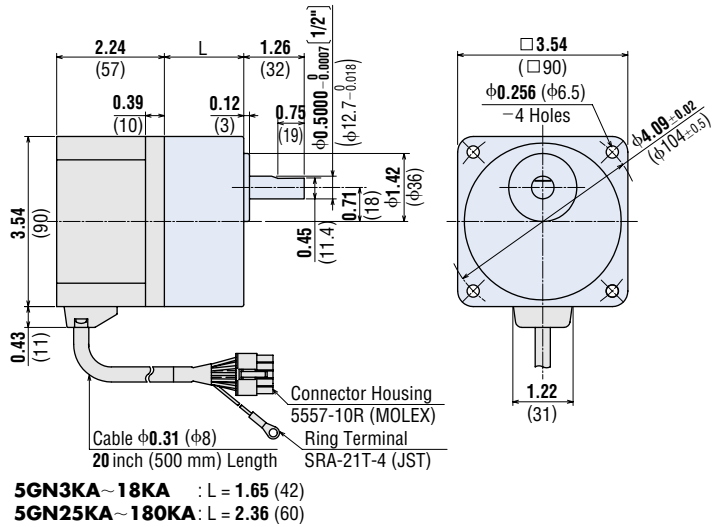

◆ Round Shaft Type

AXU540A-A, AXU540C-A, AXU540S-A Round Shaft Type

Motor: AXUM540-A

Weight: 3.1 lb. (1.4 kg)

DXF A318

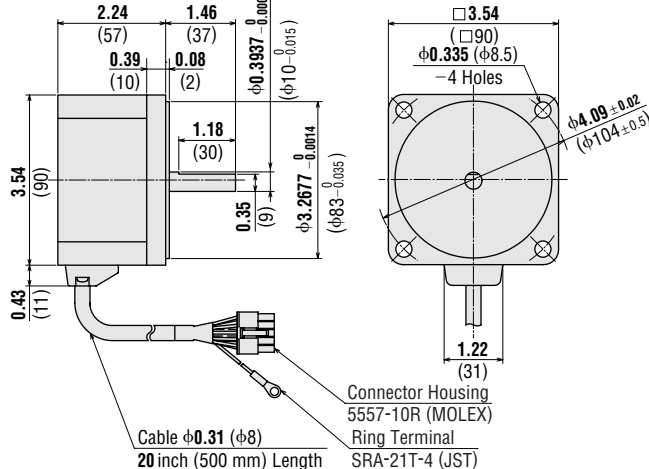

◆ Decimal Gearhead

(Can be connected to **AXU540GN** pinion shaft type.)

5GN10XK

Weight: 1.32 lb. (0.6 kg)

DXF A022

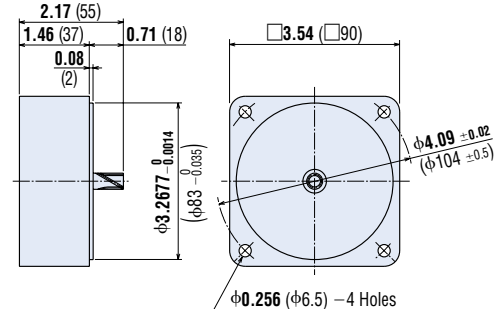

◆ Motor/Gearhead

AXU590A-GU, AXU590C-GU, AXU590S-GU Pinion Shaft Type

Motor: AXUM590-GU / Gearhead: **5GU□KA**
 Weight: 3.1 lb. (1.4 kg) / Weight: 3.3 lb. (1.5 kg)

DXF A315

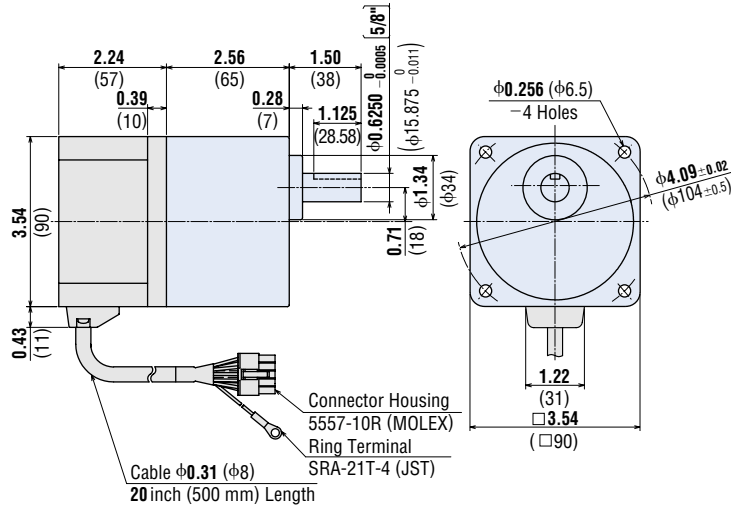

● Key and Key Slot (Scale 1/2)
 (The key is provided with the gearhead)

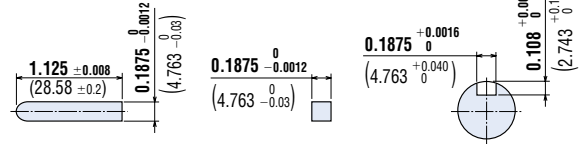

◆ Round Shaft Type

AXU590A-A, AXU590C-A, AXU590S-A Round Shaft Type

Motor: AXUM590-A
 Weight: 3.1 lb. (1.4 kg)

DXF A314

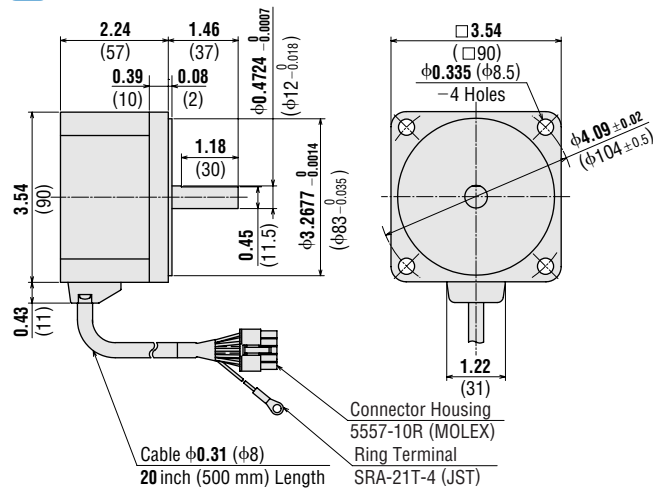

◆ Decimal Gearhead

5GU10XKB (for 5GU□KA)
5GU10XK (for 5GU□KHA)
 Weight: 1.32 lb. (0.6 kg)

DXF A029

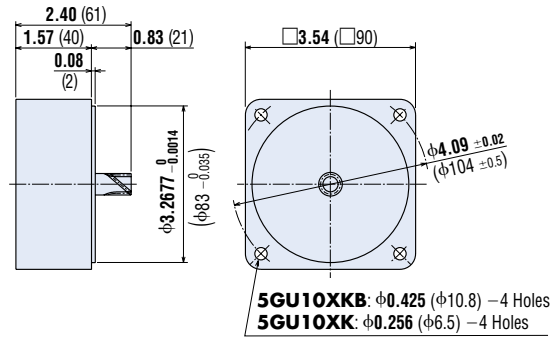

◆ High-Power Type Gearhead

5GU□KHA (For AXU590GU type)

Weight: 4.2 lb. (1.9 kg)

DXF A038U

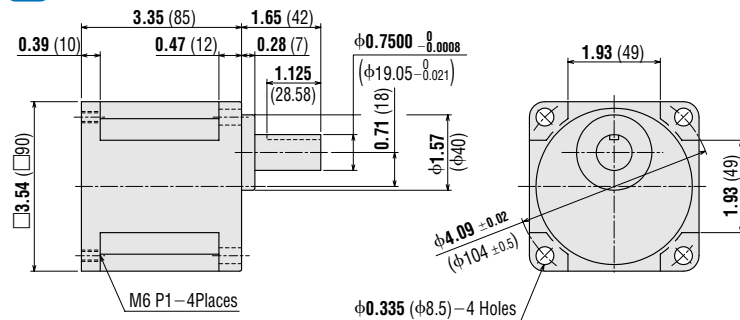

● Key and Key Slot (Scale 1/2)
 (The key is provided with the gearhead)

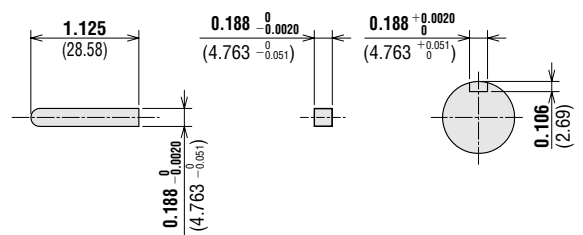

◆ **Control Unit**

AXUD10A, AXUD10C, AXUD10S
 AXUD25A, AXUD25C, AXUD25S
 AXUD40A, AXUD40C, AXUD40S
 AXUD90A, AXUD90C, AXUD90S
 Weight: 0.88 lb. (0.4 kg)

DXF A293

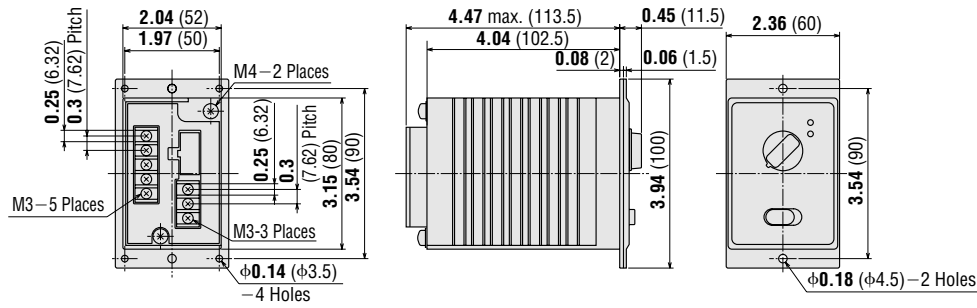

◆ **Control Unit Panel Cut-Out**

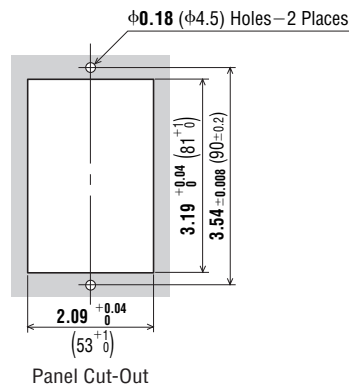

◆ **Connection Cable (included)**

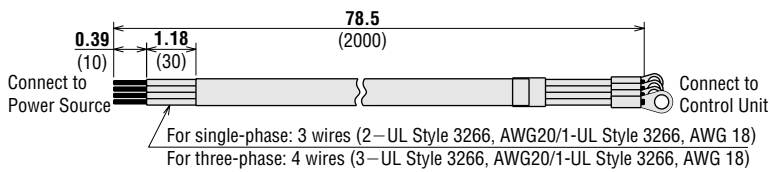

Connection and Operation

Names and Functions of Control Unit

Speed potentiometer

Turning the potentiometer clockwise causes the speed to increase.
Speed setting range is 100~2000 r/min.
The setting is 0 r/min at the time of shipment.

RUN/STAND-BY Switch

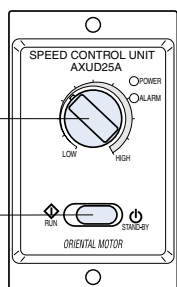

Front of Control Unit

Input/output connection signal terminals

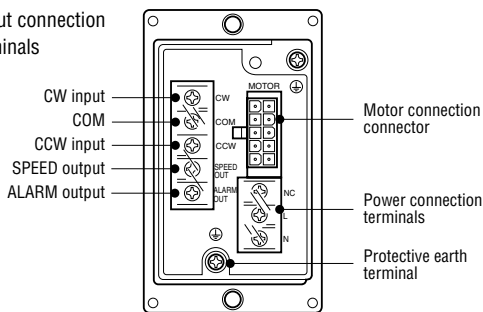

Back of Control Unit

Notes:

- The RUN/STAND-BY switch is not a power ON/OFF switch.
- When you want to stop the motor for an extended period, turn off the control unit power.

Connection Diagrams

Motor and Control Unit Connection

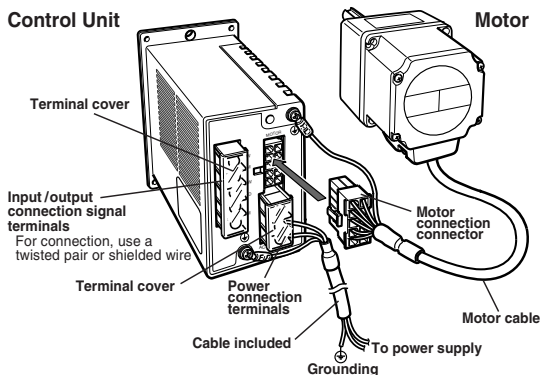

Motor Connection

Insert the motor cable connector into the motor connector (MOTOR) on the control unit. Insert it until a click sound is audible. To expand the distance between the motor and control unit, use an optional extension cable. The connection can be extended to a maximum of 34.4 feet (10.5 m).

Extension cable → Page B-57

Power Connection

Connect the included power supply cable to the power supply terminal of the control unit. When the included power supply cable is not used, use a cable with a diameter equivalent to AWG22 or more. In that case, round crimp terminals with insulation should be used.

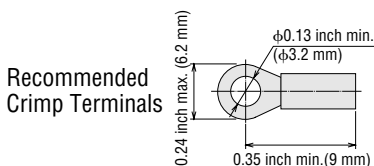

Ground

For the Protective Earth cable, use a cable with a diameter equivalent to AWG18 or more.

Operation

The direction of motor rotation is as viewed from the output shaft end of the motor. "CW" indicates clockwise direction, while "CCW" indicates counterclockwise direction.

Operation Using the RUN/STAND-BY Switch

When the RUN/STAND-BY switch is set to the "RUN" position, the motor will run. When it is set to the "STAND-BY" position, the motor will stop.

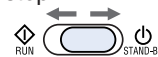

The direction of rotation depends on how the short circuit bar at the back of control unit is connected. Connect the short circuit bar between the CW and COM or CCW and COM. Do not use the short circuit bar for any other purpose.

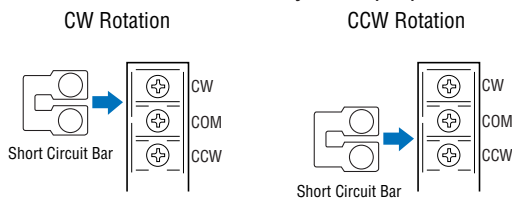

Operating Using External Signals

Set the RUN/STAND-BY switch to the "RUN" position.

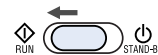

- See "Input Circuit Connection Example" shown on the next page for connection.

Timing Chart

Operating Using External Signals

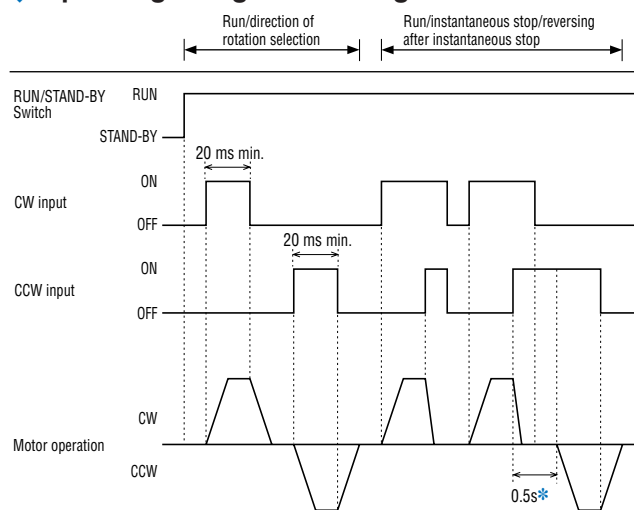

Note:
The CW and CCW input signals must be ON for at least 20 ms.

When both the CW and CCW inputs are turned on, the motor stops instantaneously.
*Motor does not run for 0.5 s after instantaneous stop, if a reversing run signal is input.

● Signal Input Circuit

◆ Input Circuit

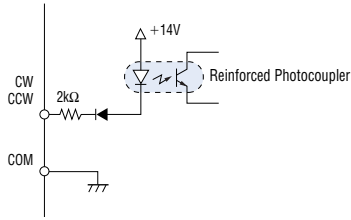

◆ Input Circuit Connection Example

Set the RUN/STAND-BY switch to the "RUN" position.

- Small-capacity switch and relay

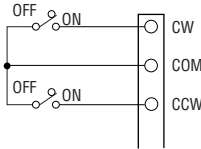

- Use a small-capacity contact type relay capable of opening and closing 12 VDC, 5 mA.
- Transistor output type controller

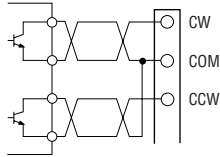

Rotation Direction of Motor

- CW (clockwise) directional operation
When CW input is turned on, the motor runs in a clockwise direction. When CW input is turned off, the motor stops.
- CCW (counterclockwise) directional operation
When CCW input is turned on, the motor runs in a counterclockwise direction. When CCW input is turned off, the motor stops.

When both the CW and CCW inputs are turned on simultaneously, the motor stops instantly. Instantaneous reversing operation is not possible.

Notes:

- Wait for more than 20 ms when changing input signals of CW and CCW.
- Do not use a solid state relay (SSR) to turn on or off power. The motor and control unit may be damaged if it is used.
- When you want to use the controller with a built-in clamp diode, pay attention to the sequence of turning on or off the power.
Power ON : Controller ON → Control Unit ON
Power OFF : Control Unit OFF → Controller OFF

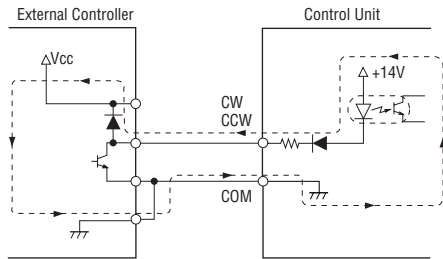

If the control unit power is turned on first when connected as shown above, or the controller power is turned off with the control unit power turned on, current will be applied, as indicated by the arrows in the diagram. This may cause the motor to run.

When the power is turned on or off simultaneously, the motor may run temporarily due to differences in power capacity. The controller power must be turned on first, and control unit power must be turned off first.

● Signal Output Circuit

◆ Output Circuit

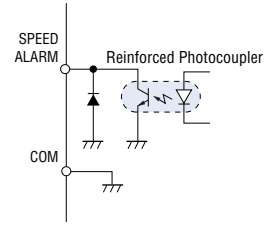

◆ Output Circuit Connection Example

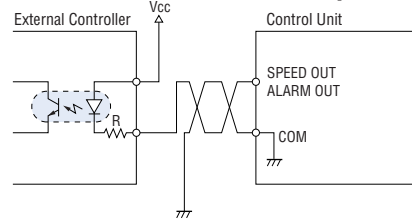

Notes:

- The signal output is Open Collector Output.
- Use the power supply of 26.4 VDC or less to connect the limit resistance (R) so that output current does not exceed 10 mA.

SPEED Output

The speed output signal is synchronized with the motor speed. The system outputs pulses (with a width of approximately 0.5 ms) at a rate of 30 pulses per rotation of the motor output shaft. You can measure the speed output frequency and calculate motor speed.

$$\text{Motor Speed (r/min)} = \frac{\text{SPEED Output Frequency [Hz]}}{30} \times 60$$

$$\text{SPEED Output Frequency (Hz)} = \frac{1}{T}$$

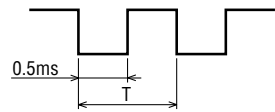

To check the reduced motor speed visually (the speed at the motor output shaft or at the gearhead output shaft), connect a speed indicator **SDM496** (sold separately). Speed Indicator → Page A-214

Notes for Connection:

- When you want to extend the input/output signal cable, the length must not exceed 6.6ft. (2m). The cable should be as short as possible in order to minimize noise.
- Signal wires and motor wires should be kept away from equipment, power cables and other sources of magnetic noise.

● Setting the Acceleration/Deceleration Time

The motor accelerates slowly when it starts up and decelerates slowly when it stops. This acceleration/ deceleration time can be set within the range from 0.5 to 10 sec (2000 r/min without load). The time can be set using the acceleration/deceleration potentiometer. Remove the front panel of control unit to access the potentiometer.

* The figure shows the control unit with the front panel removed.

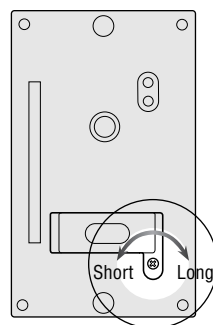

Acceleration/Deceleration time setting potentiometer

Time is increased by turning the switch clockwise. Use an insulated Phillips Screwdriver for this operation. The shortest time is selected at the time of shipment.

List of Motor and Control Unit Combinations

Pinion Shaft Type

Output Power		Model	Motor Model	Control Unit Model
HP	W			
1/75	10	AXU210A-GN	AXUM210-GN	AXUD10A
		AXU210C-GN		AXUD10C
		AXU210S-GN		AXUD10S
1/30	25	AXU425A-GN	AXUM425-GN	AXUD25A
		AXU425C-GN		AXUD25C
		AXU425S-GN		AXUD25S
1/19	40	AXU540A-GN	AXUM540-GN	AXUD40A
		AXU540C-GN		AXUD40C
		AXU540S-GN		AXUD40S
1/8	90	AXU590A-GU	AXUM590-GU	AXUD90A
		AXU590C-GU		AXUD90C
		AXU590S-GU		AXUD90S

Round Shaft Type

Output Power		Model	Motor Model	Control Unit Model
HP	W			
1/75	10	AXU210A-A	AXUM210-A	AXUD10A
		AXU210C-A		AXUD10C
		AXU210S-A		AXUD10S
1/30	25	AXU425A-A	AXUM425-A	AXUD25A
		AXU425C-A		AXUD25C
		AXU425S-A		AXUD25S
1/19	40	AXU540A-A	AXUM540-A	AXUD40A
		AXU540C-A		AXUD40C
		AXU540S-A		AXUD40S
1/8	90	AXU590A-A	AXUM590-A	AXUD90A
		AXU590C-A		AXUD90C
		AXU590S-A		AXUD90S

Accessories (Sold Separately)

Extension Cables

Model	Length: L [ft. (m)]
CC01AXU	3.3 (1)
CC02AXU	6.6 (2)
CC03AXU	9.8 (3)
CC05AXU	16.4 (5)
CC10AXU	32.8 (10)

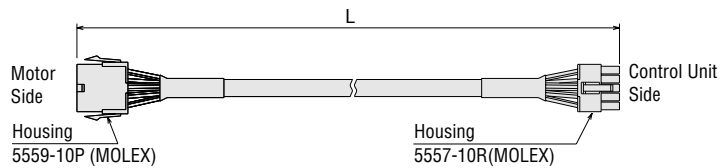

- Maximum extension length is 34.4 ft. (10.5m).