

αSTEP PLUS

Programmable Motion Control Driver

The αSTEP PLUS driver has an integrated controller which ensures a simple, efficient solution to stepping motor applications. Intelligent, integrated, and ideal for technology's increasing demand on motion control, the αSTEP PLUS is computer-programmable via an RS-232C connection.



Features

- Integrated control – separate host controller not necessary
- Simple communication
- Easy-to-use software set
- Available with round shaft αSTEP Motors (□60 mm, □85 mm)

Closed loop control means no loss of synchronism

The newly developed, built-in, rotor position detection sensor constantly monitors motor movement. If synchronism is about to be lost, closed loop control is used, eliminating missed steps.

Position Control

- Incremental mode (relative distance specification)/Absolute mode (absolute position specification)
- Linked operation (a maximum of four motion profiles may be linked)
- Data range (in pulses): –8,388,608 to +8,388,607
- Operating speed: 1 Hz to 500 kHz (set in 1 Hz increments)

Four Operation Modes

1. Positioning
2. Mechanical home seeking (+LS, –LS, HOMELS)
3. Continuous
4. Electrical home seeking

Communication

- ASCII based commands
- Conforms to RS-232C communication specifications
- Start-Stop synchronous transmission method
- Transmission speed: 9,600 bps
- Data length: 8bits, 1 stop bit, no parity
- Protocol: TTY (CR + LF)
- Modular 4-pin connector

Program Memory

- Maximum number of programs: 14 (including STARTUP)
- Maximum lines per program: 64
- Commands per line: 1
- Program variables: 26 (A to Z)

Built-in Functions

- Selectable motor-resolution
- Sensor logic
- Display values
- Run and stop current values
- Over-travel limits
- Incremental moves
- Speed-filter set value
- Software over-travel
- I/O status
- Motor rotation direction
- Alarm history
- Daisy-chain connections
- Emergency stop
- Syntax checking

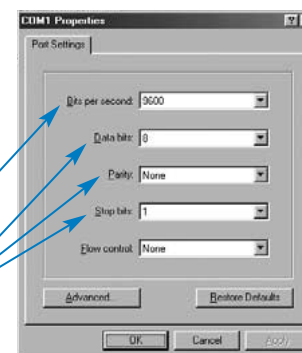

Using Windows HyperTerminal®, programming the αSTEP PLUS driver is a simple task.

Example: "PROGRAM1"

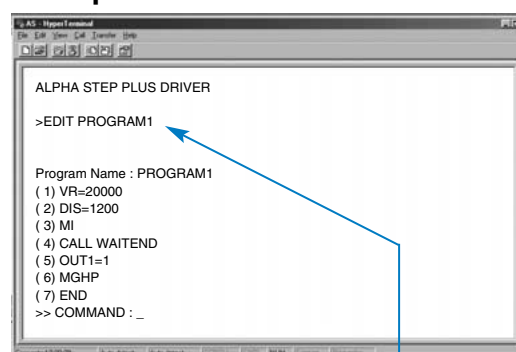

PROGRAM1 Definition

- Operating Speed: 20,000 Hz
- Move Distance: 1200 pulses
- Call a subroutine that waits for the motor to stop before moving on to the next command
- Turn On Output #1
- Incremental Move
- Seek the Mechanical Home Position in the Positive Direction
- End Program

Specification



Motor Frame Size	(mm)	60		85	
Package Model	Standard	AS66ACP	AS69ACP	AS98ACP	AS911ACP
	Electromagnetic Brake	AS66MCP	AS69MCP	AS98MCP	—
Maximum Holding Torque *1	N·m	1.2	2	2	4
Rotor Inertia *2	kg·m ²	405×10 ⁻⁷ [564×10 ⁻⁷]	802×10 ⁻⁷ [961×10 ⁻⁷]	1400×10 ⁻⁷ [1560×10 ⁻⁷]	2710×10 ⁻⁷
Stop Position Accuracy	minutes	±5			
Resolution *3		0.72°/ pulse(500 P/R) ~0.036°/ pulse(10000 P/R)			
Power Source		Single-Phase 200-230 VAC -15%~+10% 50/60Hz			
Input Current *4		3A	3.9A	3.5A	4.5A
Electromagnetic Brake *5	Type	Active when power is off			
	Power Supply Input	DC24V ±5%			
	Power Consumption W	6			
	Excitation Current A	0.25			
	Static Friction Torque N·m	0.6	1	1	—
Dimensions No.	Motor	1		2	
	Driver	3			

- *1 Maximum holding torque refers to the holding torque at motor standstill when the rated current is supplied to the motor. Use this value to compare motor torque performance. When using the motor with the dedicated driver, the driver's "Automatic Current Cutback" function at motor standstill reduces maximum holding torque by approximately 50%.
 - *2 [] represents the specification of electromagnetic brake type.
 - *3 The resolution can be set from 500 P/R to 10000 P/R by setting parameters.
 - *4 The input current value represents the maximum current. (The input current varies according to the pulse frequency, load torque.)
 - *5 The electromagnetic brakes are for holding the position when the power is off. They can not be used for complicated braking. Also, a separate 24 VDC ±5%, 0.3 A minimum power supply is required for the electromagnetic brakes.
- When you use electromagnetic brake type, extension cable (sold separately) is necessary.

Speed — Torque Characteristics

AS66ACP AS66MCP

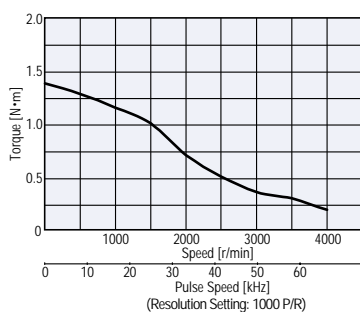

AS69ACP AS69MCP

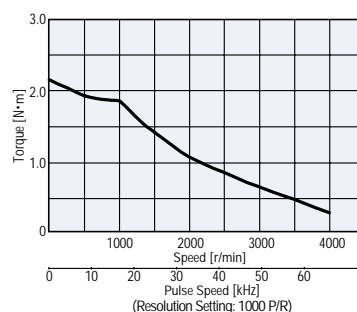

AS98ACP AS98MCP

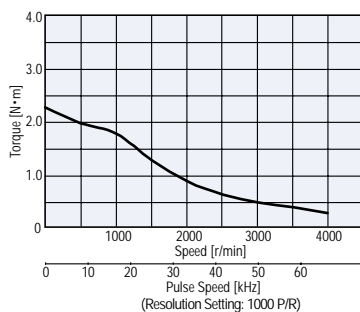

AS911ACP

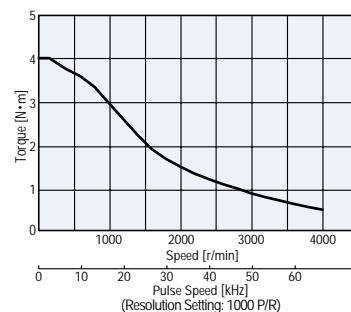

Notes :

- Pay attention to heat dissipation from motor and driver. The motor will produce a considerable amount of heat under certain conditions. Be sure to keep the temperature of the motor case under 100°C. [Under 75°C is required to comply with UL or CSA standards.]
- When using the motor with the dedicated driver, the driver's "Automatic Current Cutback" function at motor standstill reduces maximum holding torque by approximately 50%.

Dimensions scale 1/4, unit = mm

● Motor

1 Motor Frame Size: □60 mm

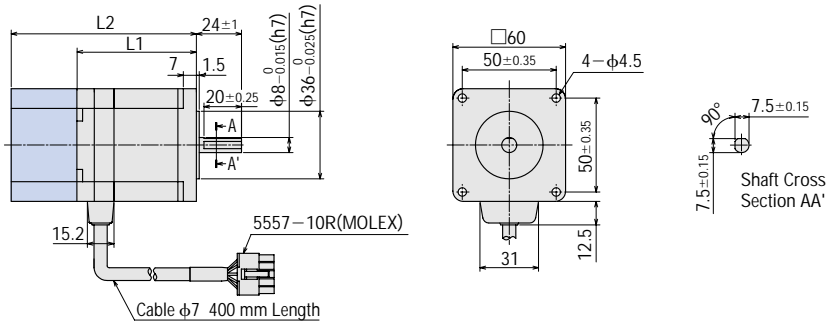

Model	Motor Model	L1 (mm)	L2 (mm)	Mass (kg)	Driver Model
AS66ACP	ASM66AC	63.6	—	0.85	ASD12A-CP
AS66MCP	ASM66MC	—	98.6	1.1	ASD12A-CP
AS69ACP	ASM69AC	94.6	—	1.4	ASD16D-CP
AS69MCP	ASM69MC	—	129.6	1.65	ASD16D-CP

• When applying your equipment for UL standards, please contact your nearest Oriental Motor sales office.

2 Motor Frame Size: □85 mm

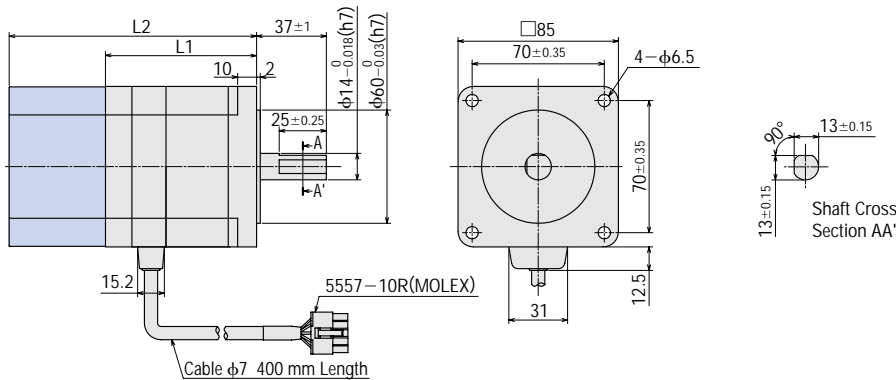

Model	Motor Model	L1 (mm)	L2 (mm)	Mass (kg)	Driver Model
AS98ACP	ASM98AC	80	—	1.8	ASD16A-CP
AS98MCP	ASM98MC	—	131	2.2	ASD16A-CP
AS911ACP	ASM911AC	110	—	3	ASD20A-CP

• When applying your equipment for UL standards, please contact your nearest Oriental Motor sales office.

● Driver

3 Mass: 0.8kg

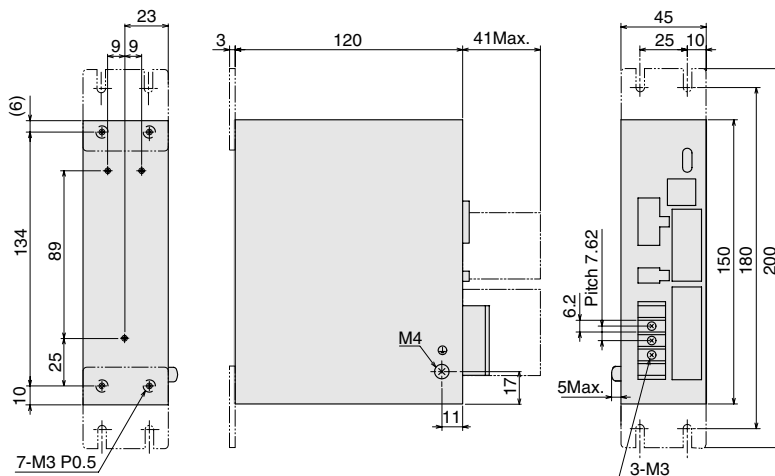

● Mounting Bracket (2 Pieces, included)

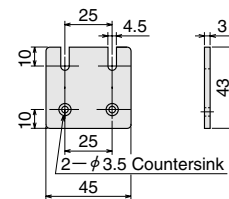

● I/O Connector (Included)

Connector (36 pin): 54306-3611 (MOLEX) for CN4
 Cover Assembly (36 pin): 54331-1361 (MOLEX) for CN4
 Connector (20 pin): 54306-2011 (MOLEX) for CN5
 Cover Assembly (20 pin): 54331-1201 (MOLEX) for CN5

Accessories (Sold Separately)

Driver Cables

Model	Length m	Connector
CC20D1-1	1	20-pins Sensor CN5
CC20D2-1	2	
CC36D1-1	1	36-pins I/O CN4
CC36D2-1	2	

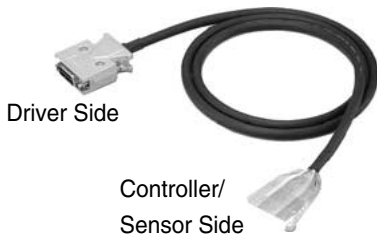

Communications Cable

Used to connect computer and **αSTEPPLUS** Driver through an RS232C connection.

Model	Length m
FC04W5	5

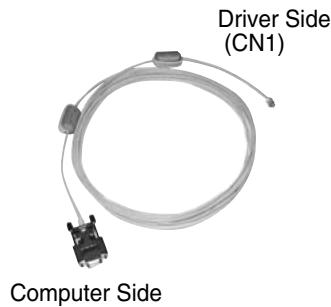

Mounting Brackets

Useful for maintaining proper alignment between the motor shaft and the load.

Material: Die cast aluminum

Mounting Bracket Models	αSTEPPLUS Models
PAL2P-5	AS66ACP AS66MCP AS69ACP AS69MCP
PAL4P-5	AS98ACP AS98MCP AS911ACP



The mounting bracket base is built with holes large enough to allow for horizontal alignment adjustments. (Adjustable range: Approximately 6 mm)



This product is manufactured at a plant certified with the international standards **ISO 9001** (for quality assurance) and **ISO 14001** (for systems of environmental management).

Specifications subject to change without notice.

This catalogue was published in February 2005.

ORIENTAL MOTOR (EUROPA) GmbH

www.orientalmotor.de

European Headquarters and Düsseldorf Office

Schiessstr. 74
40549 Düsseldorf, Germany
Tel: 0211-5206700 Fax: 0211-52067099

Munich Office

Liebigstr. 14
85757 Karlsfeld, Germany
Tel: 08131-59880 Fax: 08131-598888

Hamburg Office

Meckelfelder Weg 2
21079 Hamburg, Germany
Tel: 040-76910443 Fax: 040-76910445

Stuttgart Office

Tel: 07335-924853 Fax: 07335-924854

ORIENTAL MOTOR (UK) LTD.

www.oriental-motor.co.uk

Unit 5 Faraday Office Park,
Rankine Road, Basingstoke,
Hampshire RG24 8AH U.K.
Tel: 01256-347090 Fax: 01256-347099

ORIENTAL MOTOR (FRANCE) SARL

www.orientalmotor.fr

France Headquarters
32, Avenue de l'Île Saint-Martin
92737 Nanterre Cedex, France
Tel: 01 47 86 97 50 Fax: 01 47 82 45 16

Lyon Office

10, Allée des Sorbiers
69673 Bron Cedex, France
Tel: 04 78 41 15 02 Fax: 04 78 41 15 90

ORIENTAL MOTOR ITALIA s.r.l.

www.orientalmotor.it

Italy Headquarters

Via A. De Gasperi, 85
20017 Mazzo di Rho(MI), Italy
Tel: 02-9390-6346 Fax: 02-9390-6348

Bologna Office

Tel: 051-6931249 Fax: 051-6929266

ORIENTAL MOTOR CO.,LTD.

www.orientalmotor.co.jp/

Headquarters

16-17, Ueno 6-chome
Taito-ku, Tokyo 110-8536, Japan
Tel: (03)3835-0684 Fax: (03)3835-1890

For more information please contact: